

S/M No. : FR520NT010

DAEWOO

Service Manual

Refrigerator

Model: FR-520NT
FR-550NT



DAEWOO ELECTRONICS CO., LTD.

SAFETY AND PRECAUTIONS

- 1) For starters, be sure to check any chances of the leakage of electricity.
- 2) You could handle a part in the vicinity of electricity after unplugging.
- 3) You should put on rubber gloves to prevent an electric shock on operation test.
- 4) Make sure the rated current, voltage, capacity before using an instrument.
- 5) Keep your wet hands away from the metal goods in the freezer compartment not to be frostbitten.
- 6) Be careful not to let water to permeate the electric part in the machine room.
- 7) With the door open during your repair, you might be hurt by that door.
- 8) You should give a tilt to the refrigerator for your safe after removing the breakable goods inside the refrigerator.
- 9) You'd better use gloves if you fix it up around the evaporator.

TABLE OF CONTENTS

EXTERNAL VIEWS	2
1. FR-520NT	2
2. FR-550NT	3
SPECIFICATIONS	4
1. OUTLINE	4
2. ELECTRIC PARTS	5
3. POWER CORD	9
4. DOOR COLOR	10
OPERATION AND FUNCTIONS	11
DIAGRAM	16
1. WIRNIG DIAGRAM	16
2. PARTICAL WIRING DIAGRAM	17
3. CIRCUIT DIAGRAM	18
4. AIR FLOW DIAGRAM	19
5. REFRIGRANT CYCLE DIAGRAM	20
DISASSEMBLY AND ASSEMBLY	21
1. FREEZER LOUVER	21
2. CONTROL SWITCH IN REFRIGERATOR ROOM	23
EXPLODED VIEW AND PARTS LIST	24
1. TOTAL EXPLODED VIEW	24
2. TOTAL PARTS LIST	25
3. MACHINE ROOM EXPLODED VIEW AND PARTS LIST	28

EXTERNAL VIEWS

1. FR-520NT

1) EXTERNAL SIZE

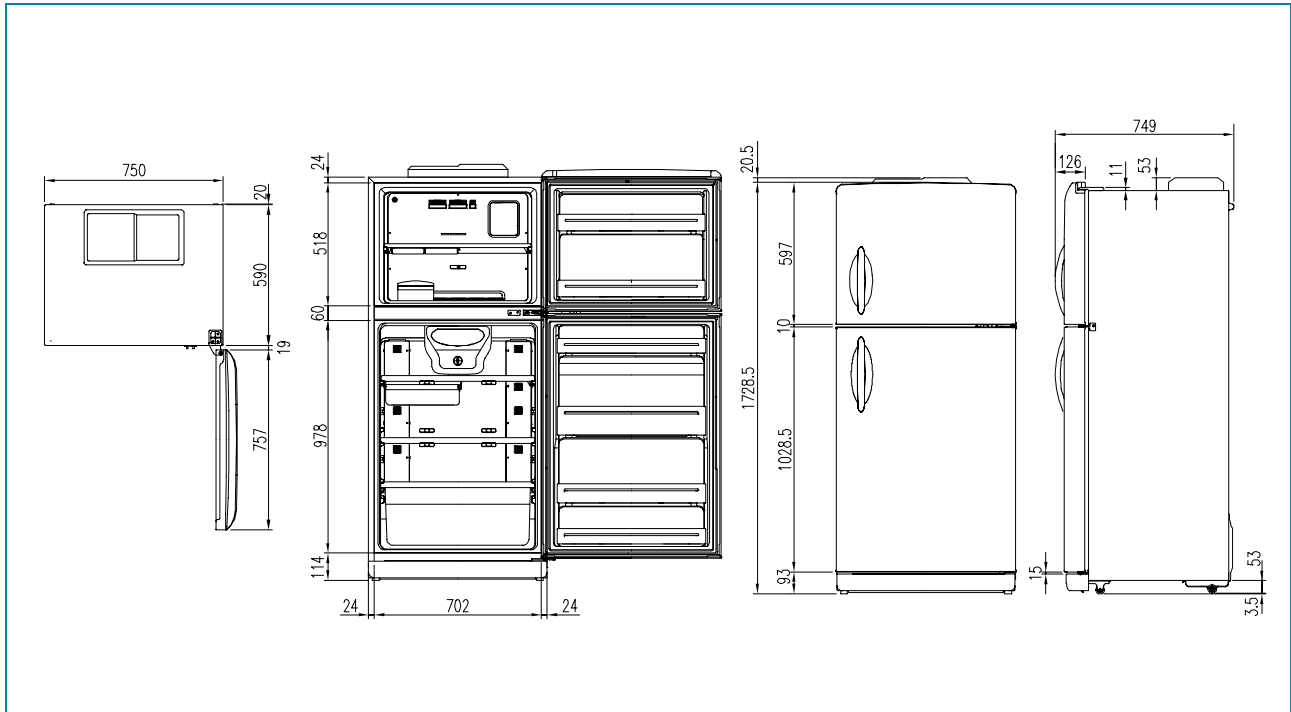

2) NAME OF PARTS

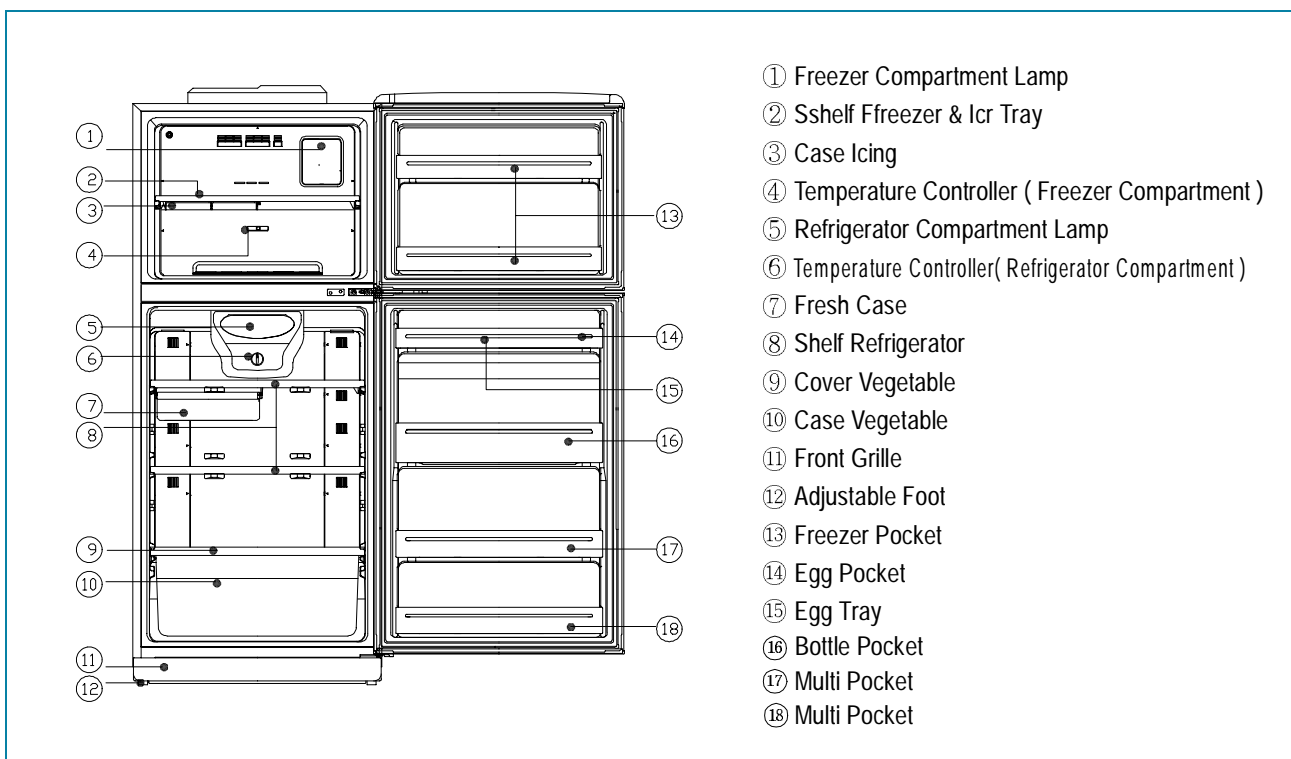

2. FR-550NT

1) EXTERNAL SIZE

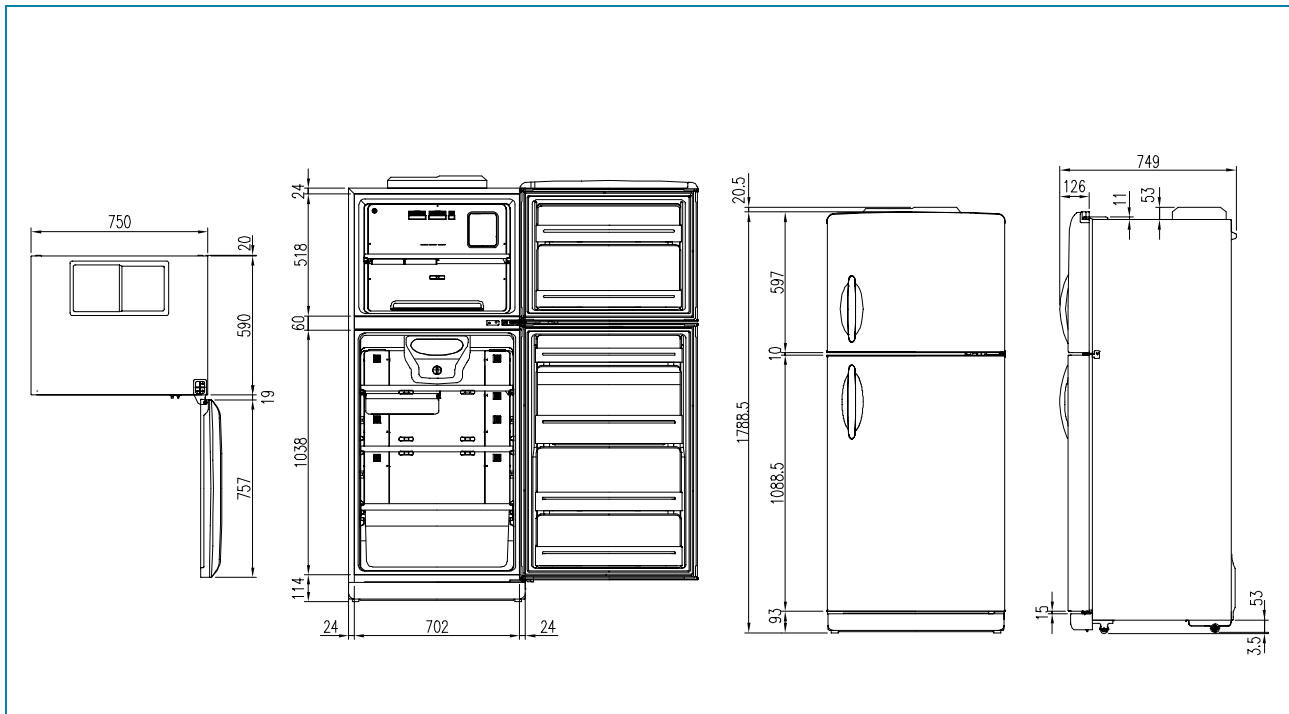

2) NAME OF PARTS

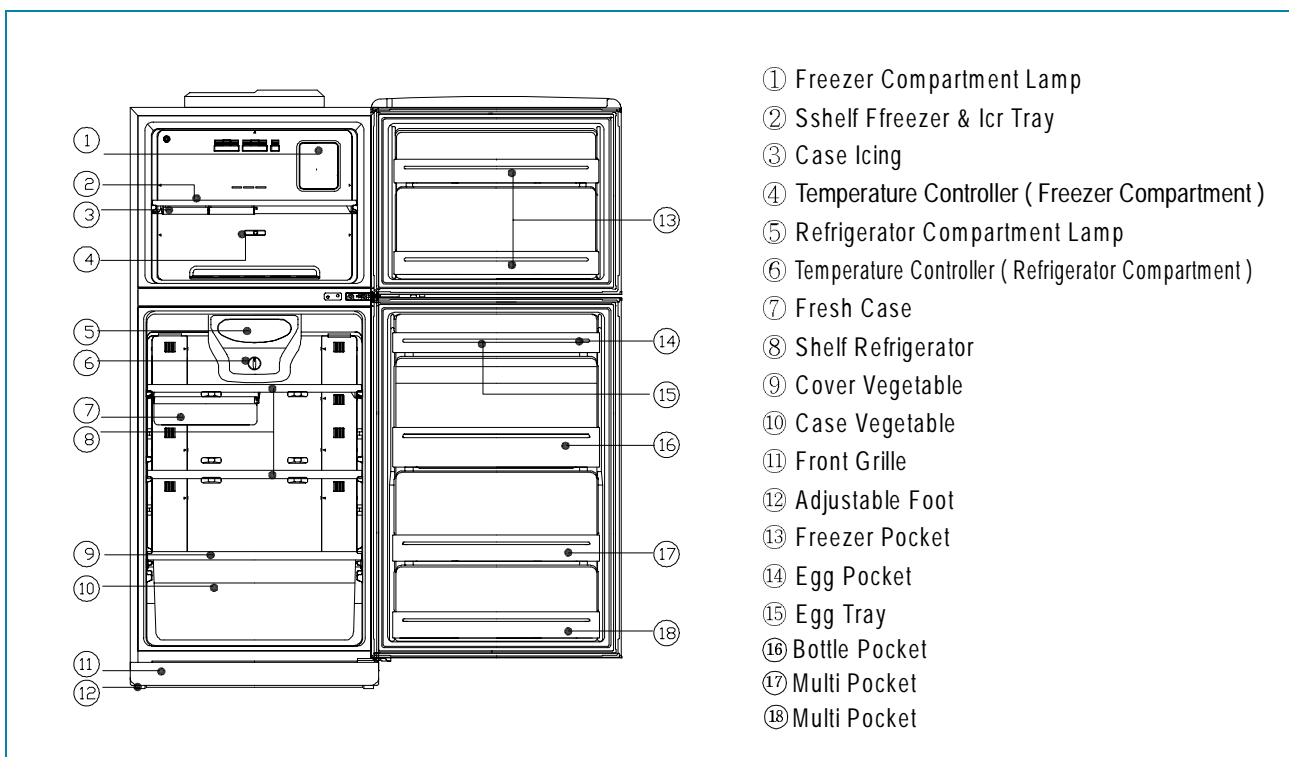

SPECIFICATIONS

1. OUTLINE

DIVISION		CONTENTS	CONTENTS
MODEL NAME		FR-520NT	FR-550NT
USABLE CAPACITY	FREEZER	122 ℓ	122 ℓ
	REFRIGERATOR	318 ℓ	352 ℓ
	TOTAL	440 ℓ	474 ℓ
EXTERNAL DIMENSION	WIDTH	757mm	757mm
	DEPTH	750mm	750mm
	HEIGHT	1749mm	1809mm
REFRIGERANT	R12	170g	170g
	R134a	140g	140g
COOLING & CONTROL SYSTEM	COOLING SYSTEM	Fan Cooling System	Fan Cooling System
	DEFROST SYSTEM	Fin Evaporator Forced	Fin Evaporator Forced
	DEFORST CONTROL	Automatic Start & Stop	Automatic Start & Stop
NET WEIGHT		71Kg	72Kg

2. ELECTRIC PARTS

1) COMPRESSOR

REFRIGERANT	R12							
VOLTAGE(V/HZ)	100/50, 60	110/60	115,120/60	127/60	220/50	220/60	230/50	240/50
COMP MODEL	X	BL27YE-3	X	X	SL28YE-5	PL23YG-4	SL-28YE-5	SL28YE-5
PART CODE	X	3952127A30	X	X	3954128A50	3956123G40	3954128A50	3954128A50
STARING TYPE	X	CSR	X	X	RSIR	RSCR	RSIR	RSIR

REFRIGERANT	R134a							
VOLTAGE(V/HZ)	100/50, 60	110/60	115,120/60	127/60	220/50	220/60	230/50	240/50
COMP MODEL	X	HBL25YG-3	X	X	HPL27YG1-5	X	HPL27YG1-5	HPL27YG1-5
PART CODE	X	3952125R30	X	X	3956127R51	X	3956127R51	3956127R51
STARING TYPE	X	CSR	X	X	RSCR	X	RSCR	RSCR

2) RELAY

REFRIGERANT		R12							
VOLTAGE(V/HZ)		100/50, 60	110/60	115,120/60	127/60	220/50	220/60	230/50	240/50
ASSY	TYPE NAME	X	444THBZZ-52	X	X	276THBYY-52	174THBYY-52	276THBYY-52	276THBYY-52
	PART CODE	X	3018119300	X	X	3018119350	3018119200	3018119350	3018119350
PTC	RESISTANCE	X	S068	X	X	S220	S330	S220	S220
	PART CODE	X		X	X				
OVER LOAD	PART NAME	X	444THB	X	X	276THB	174THB	276THB	276THB

REFRIGERANT		R134a							
VOLTAGE(V/HZ)		100/50, 60	110/60	115,120/60	127/60	220/50	220/60	230/50	240/50
ASSY	TYPE NAME	X	783NHBZZ-52	X	X	265NHBYY-52	X	265NHBYY-52	265NHBYY-52
	PART CODE	X	3018119380	X	X	3018119470	X	3018119470	3018119470
PTC	RESISTANCE	X	S220	X	X	S330	X	S330	S330
	PART CODE	X		X	X		X		
OVER LOAD	PART NAME	X	783NHB	X	X	265NHB	X	265NHB	265NHB

3) STARTING CAPACITOR

REFRIGERANT	R12							
VOLTAGE(V/HZ)	100/50, 60	110/60	115,120/60	127/60	220/50	220/60	230/50	240/50
PART CODE	X	401RD35050	X	X	X	X	X	X
RATED VOLTAGE	X	200V	X	X	X	X	X	X
RATED CAPACITANCE	X	100 μ F	X	X	X	X	X	X

REFRIGERANT	R134a							
VOLTAGE(V/HZ)	100/50, 60	110/60	115,120/60	127/60	220/50	220/60	230/50	240/50
PART CODE	X	401RD35050	X	X	X	X	X	X
RATED VOLTAGE	X	200V	X	X	X	X	X	X
RATED CAPACITANCE	X	100 μ F	X	X	X	X	X	X

4) RUNNING CAPACITOR

REFRIGERANT	R12							
VOLTAGE(V/HZ)	100/50, 60	110/60	115,120/60	127/60	220/50	220/60	230/50	240/50
PART CODE	X	400EL15130	X	X	X	400EL15110	X	X
RATED VOLTAGE	X	230V	X	X	X	350V	X	X
RATED CAPACITANCE	X	10 μ F	X	X	X	5 μ F	X	X

REFRIGERANT	R134a							
VOLTAGE(V/HZ)	100/50, 60	110/60	115,120/60	127/60	220/50	220/60	230/50	240/50
PART CODE	X	3961800400	X	X	400EL15110	X	400EL15110	400EL15110
RATED VOLTAGE	X	300V	X	X	350V	X	350V	350V
RATED CAPACITANCE	X	7 μ F	X	X	5 μ F	X	5 μ F	5 μ F

5) F-FAN MOTOR

REFRIGERANT	R12, 134a							
VOLTAGE(V/HZ)	100/50, 60	110/60	115,120/60	127/60	220/50	220/60	230/50	240/50
TYPE NAME	S6111BDF01	S6111EDF01	X	X	S6111WDF01	IS-3211DWBFE-2	S6111WDF01	S6111WDF01
PART CODE	30159008710	3015900740	X	X	3015900730	3015900700	3015900730	3015900730
REVOLUTION	2200RPM	2200RPM	X	X	2200RPM	2200RPM	2200RPM	2200RPM

6) C-FAN MOTOR

REFRIGERANT	R12, 134a							
VOLTAGE(V/HZ)	100/50, 60	110/60	115,120/60	127/60	220/50	220/60	230/50	240/50
TYPE NAME	X	S6111EEC02	X	X	S6111WEC02	S6111UEC01	S6111WEC02	S6111WEC02
PART CODE	X	3015905030	X	X	3015905020	3015900600	3015905020	3015905020
REVOLUTION	X	2400RPM	X	X	2400RPM	2400RPM	2400RPM	2400RPM

7) DEFROST HEATER

REFRIGERANT	R12, 134a							
VOLTAGE(V/HZ)	100/50, 60	110/60	115,120/60	127/60	220/50	220/60	230/50	240/50
SPEC(W)	X	148W	148W	148W	148W	148W	148W	148W
PART CODE	X	3012803220	3012803220	3012803220	3012804600	3012804600	3012804600	3012804600

8) LAMP ASSEMBLY

REFRIGERANT	R12, 134a							
VOLTAGE(V/HZ)	100/50, 60	110/60	115,120/60	127/60	220/50	220/60	230/50	240/50
SPEC(W)	X	15W	X	X	15W	15W	15W	15W
PART CODE	X	3013600010	X	X	3013600080	3013600080	3013600080	3016800080

9) PCB TRANSFORMER

REFRIGERANT	R12, 134a							
VOLTAGE(V/HZ)	100/50, 60	110/60	115,120/60	127/60	220/50	220/60	230/50	240/50
TYPE NAME	RT30	RT30	RT30	RT30	RT30	RT30	RT30	RT30
PART CODE	5EPK057770	5EPK057780	5EPK057780	5EPK057780	5EPK057790	5EPK048004	5EPK057810	5EPK057790

10) MAIN PCB ASSEMBLY

REFRIGERANT	R12, 134a							
VOLTAGE(V/HZ)	100/50, 60	110/60	115,120/60	127/60	220/50	220/60	230/50	240/50
TYPE NAME	X	RT30	RT30	RT30	RT30	RT30	RT30	RT30
PART CODE	X	3014381040	3014381040	3014381040	3014381020	3014381010	3014381030	3014381020

SPECIFICATIONS

11) DRYER

REFRIGERANT	R12	R134a
SPEC (g)	10g	15g
PART CODE	3016801000	3016801010

12) FUSE (PCB)

REFRIGERANT	R12, 134a							
VOLTAGE(V/Hz)	100/50, 60	110/60	115,120/60	127/60	220/50	220/60	230/50	240/50
RATED CURRENT	X	250V/1.6A	X	250V/1.6A	250V/1.6A	250V/1.6A	250V/1.6A	250V/1.6A
PART CODE	X	5F3GB1682R	X	5F3GB1682R	5F3GB1682R	5F3GB1682R	5F3GB1682R	5F3GB1682R

13) TEMPERATURE FUSE

REFRIGERANT	R12, 134a							
VOLTAGE(V/Hz)	100/50, 60	110/60	115,120/60	127/60	220/50	220/60	230/50	240/50
OPERATING TEMPERATURE	X	77°C	X	X	77°C	77°C	77°C	77°C
PART CODE	X	3017200400	X	X	3017200400	3017200400	3017200400	3017200400

14) DOOR S/W

REFRIGERANT	R12, 134a							
VOLTAGE(V/Hz)	100/50, 60	110/60	115,120/60	127/60	220/50	220/60	230/50	240/50
PART CODE	X	3018100010	3018100010	3018100010	3018100010	3018100010	3018100010	3018100010

3. POWER CORD

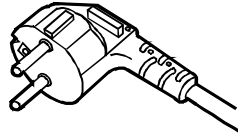
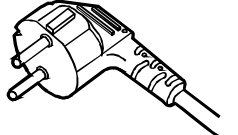
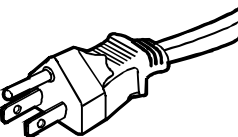
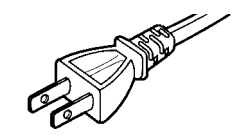
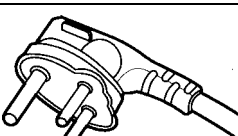
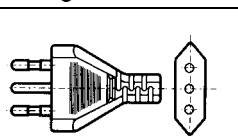
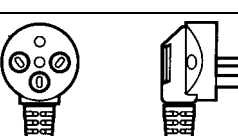
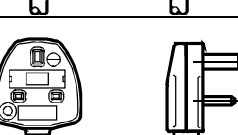
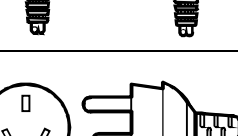
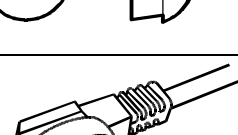
NO	SHAPE OF CODE	PART CODE	DESCRIPTION	REMARK
1		3011315000	CP-2PIN	FOR EUROPEAN COUNTRY
2		401RA17200	CP-2PIN	FOR OTHER COUNTRY
3		4006D17101	KP-30	FOR AMERICA
4		401PD17101	KP-211	FOR JAPAN & TAIWAN
5		3011300801	BP-3PIN	
6		3011303010	#267	FOR CHILE
7		3011315310		FOR ISRAEL
8		3011303050	BS-1363A	FOR U.K, MIDDLE ASIA SINGAPORE & MALAYSIA
9		3011301200	KP551/550	FOR CHINA & AUSTRALIA
10		3011301120	FLAP TYPE KP-551	NEC in AUSTRALIA

Upper power cord's part code is only for lead wire, without any kinds of terminal or housing

4. DOOR COLOR

1) ASSEMBLY URETHAN FREEZER DOOR(FR-520NT, 550NT)

① NON-KEY TYPE

REFRIGERANT	R12				R134a			
COLOR TYPE	Dull lamina sheet	High-glossy Lamina sheet	Normal PCM	High-glossy Bright PCM	Dull lamina sheet	High-glossy Lamina sheet	Normal PCM	High-glossy Bright PCM
PART CODE	X	3010075100	X	X	X	3010075110	X	X

② KEY TYPE

REFRIGERANT	R12				R134a			
COLOR TYPE	Dull lamina sheet	High-glossy Lamina sheet	Normal PCM	High-glossy Bright PCM	Dull lamina sheet	High-glossy Lamina sheet	Normal PCM	High-glossy Bright PCM
PART CODE	X	3010075100	X	X	X	3010075110	X	X

2) ASSEMBLY URETHAN REFRIGERATOR DOOR

① FR-520NT

- NON-KEY TYPE

REFRIGERANT	R12				R134a			
COLOR TYPE	Dull lamina sheet	High-glossy Lamina sheet	Normal PCM	High-glossy Bright PCM	Dull lamina sheet	High-glossy Lamina sheet	Normal PCM	High-glossy Bright PCM
PART CODE	X	3010079100	X	X	X	3010079140	X	X

- KEY TYPE

REFRIGERANT	R12				R134a			
COLOR TYPE	Dull lamina sheet	High-glossy Lamina sheet	Normal PCM	High-glossy Bright PCM	Dull lamina sheet	High-glossy Lamina sheet	Normal PCM	High-glossy Bright PCM
PART CODE	X	3010079150	X	X	X	3010079160	X	X

② FR-550NT

- NON-KEY TYPE

REFRIGERANT	R12				R134a			
COLOR TYPE	Dull lamina sheet	High-glossy Lamina sheet	Normal PCM	High-glossy Bright PCM	Dull lamina sheet	High-glossy Lamina sheet	Normal PCM	High-glossy Bright PCM
PART CODE	X	3010079110	X	X	X	3010079130	X	X

- KEY TYPE

REFRIGERANT	R12				R134a			
COLOR TYPE	Dull lamina sheet	High-glossy Lamina sheet	Normal PCM	High-glossy Bright PCM	Dull lamina sheet	High-glossy Lamina sheet	Normal PCM	High-glossy Bright PCM
PART CODE	X	3010079170	X	X	X	3010079180	X	X

OPERATION AND FUNCTIONS







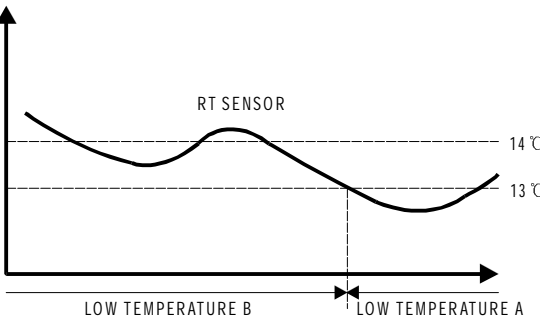

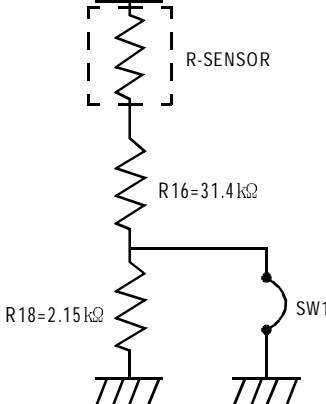

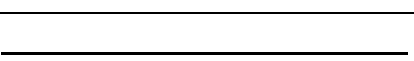

NO	CONTROL FUNCTION	CONTROL OBJECTS	CONTENTS	REMARK
1	Temperature Regulation	COMP Fan	<p>1. Temperature Regulation of Fresh Food Compartment</p> <ol style="list-style-type: none"> 1) Maximum angle clockwise : Temperature setting for WINTER 2) Maximum angle counter-clockwise : Temperature setting for MIN 3) Maximum rotation angle : $280 \pm 10^\circ$ 4) Minimum Step Difference : $0.35^\circ\text{C} / 20^\circ$ 5) Total Step Difference : 5°C <div data-bbox="651 600 1107 1055" data-label="Diagram"> </div> <p>2. Temperature Regulation of Freezer Compartment</p> <ol style="list-style-type: none"> 1) Temperature is regulated by moving the lever to the left and/or the right. 2) Temperature has nothing to do with PCB control. 	
2	Control of Temperature	COMP Fan	<p>1. How to Control</p> <ol style="list-style-type: none"> 1) COMP is controlled by On/Off point of R-Sensor at each mode. 2) Middle Off Point of Fresh Food Compartment : 3.5°C 3) On/Off Difference of Freezer Compartment : 1.0°C 4) Fan Delay : Fan is On/Off after 1 minute of Comp On/Off. 5) Step Difference of Fresh Food Compartment <p>MIN ↔ MED : 2°C MED ↔ MAX : 2°C MAX ↔ WINTER : 1°C</p> <div data-bbox="635 1568 1260 2011" data-label="Figure"> </div>	

OPERATION AND FUNCTIONS

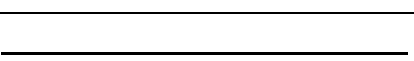
NO	CONTROL FUNCTION	CONTROL OBJECTS	CONTENTS	REMARK
3	Optional Function	Temperature	<p>1. Option for Weak Refrigeration</p> <p>1) SW1 On : Standrd On/Off applied</p> <p>2) SW1 Off : 1.5 °C lower than Standard On/Off</p> <p>2. Option for Middle Off Point of Fresh Food Compartment</p> <p>1) J01 (O), R01 (O), R02 (O) : 3 °C</p> <p>2) J01 (X), R01 (O), R02 (O) : 3.5 °C</p> <p>3) J01 (X), R01 (O), R02 (X) : 4.5 °C</p> <p>3. Option for On/Off Difference of Fresh Food Compartment</p> <p>1) J02 (O), J03 (O), R04 (O) : 0.5 °C</p> <p>2) J02 (X), J03 (O), R04 (O) : 3.5 °C</p> <p>3) J02 (X), J03 (O), R04 (X) : 4.5 °C</p> <p>4. Option for Fan Delay</p> <p>1) JP03 (O) : Fan On/Off after 1 minute of Comp On/Off</p> <p>2) JP03 (X) : Comp and Fan On/Off are linked(co-working).</p>	
4	Defrosting Period	Defrosting Mode	<p>1. Determination of Defrosting Period</p> <p>1) Total Run-time of Comp : 6, 8, 10 hours</p> <p>2) Run-ratio of Comp : over 80%</p> <p>3) Any Error : R1, D1, D2, C1</p> <p>4) Total Time : 60 hours</p> <p>2. Explanation</p> <p>1) Defrosting starts if any Error happes or the run-ratio of Comp is over 80%, when the total run-time of Comp is over 6 hours.</p> <p>2) Defrosting starts if the run-ratio of Comp is over 80 %, when the total run-time of Comp is over 8 hours.</p> <p>3) Defrosting starts unconditionally if the total run-time of Comp is 10 hours, in case that any condition of 1) and 2) is not satisfied.</p> <p>4) Defrosting starts immediately if total time(Comp On Time+Comp Off Time) is over 60 hours, in case that any condition of 1), 2) and 3) is not satisfied.</p>	

NO	CONTROL FUNCTION	CONTROL OBJECTS	CONTENTS	REMARK
5	Defrosting Mode	Comp Fan Heater	<p>※ Normal Defrosting</p> <p>1. Starting by Defrosting Period</p> <p>2. How to Proceed</p> <p>1) Pre-Cool</p> <p>① Control Object : Comp On, Fan On, Heater Off</p> <p>② Proceeding Time : 25 minutes</p> <p>③ Terminating Condition : if R-Sensor temperature is below Middle-Off -1℃</p> <p>2) Heater Defrosting</p> <p>① Control Object : Comp Off, Fan Off, Heater On</p> <p>② Limit Proceeding Time</p> <ul style="list-style-type: none"> • 30 seconds : continuous Heater-On regardless of D-Sensor temperature (right after the starting of Defrosting) • 30 minutes : D1 Error (D-Sensor Disconnection/Short-circuit) • 80 minutes : Normal control state <p>③ Terminating Condition : Heater Off if D-Sensor temperature is over 10 ℃</p> <p>④ D2 Error : when Heater returns by limit time (30 minutes or 80 minutes)</p> <p>3) Pause</p> <p>① Control Object : Comp Off, Fan Off, Heater Off</p> <p>② Proceeding Time : 4 minutes</p> <p>4) Fan Delay</p> <p>① Control Object : Unconditional Comp On, Fan Off, Heater Off"</p> <p>② Proceeding Time : 4 minutes (In case of the Option Mode for Comp-Fan Connection Working, Fan Delay is omitted.)</p> <p>PRE-COOL → HEATER DEFROSTING → PAUSE → FAN DELAY → NORMAL RUN</p> <p>※ Compulsory Defrosting of Heater in A/S(After Service)</p> <p>1. How to start ; the defrosting begins by pressing Defrosting Key 5 times.</p> <p>2. How to proceed</p> <p>1) Same as Normal Defrosting by omitting Pre-cool Mode</p> <p>2) Heater On unconditionally for the first 30 seconds regardless of D-Sensor temperature</p>	
6	Action for Low Temperature of Compartments	R-Heater Comp Fan	<p>1. Conditions for Low Temperature</p> <p>1) Low Temperature A : RT-Sensor $\leq 13^{\circ}\text{C}$</p> <p>2) Low Temperature B : $14^{\circ}\text{C} \leq \text{RT-Sensor} \leq 19^{\circ}\text{C}$</p> <p>3) Sensing Difference of Low Temp. A, B : 1°C</p> 	

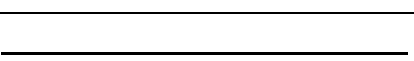
NO	CONTROL FUNCTION	CONTROL OBJECTS	CONTENTS	REMARK
			2. How to control 1) Conditions for Low Temp. A ① R-Heater Off when Comp On ② R-Heater On when Comp Off ③ 20 seconds of preventing time for re-start of Comp ④ R-Heater Off, if it is not the Low Temp. A or if it is RT-Sensor Disconnection/Short-circuit) 2) Conditions for Low Temp. B ① Middle On/Off Point -1°C when Comp is running	
7	Initial Defrosting	Defrosting Mode	1. If D-Sensor temperature $\leq 3.5^{\circ}\text{C}$ in the initial power input, normal defrosting mode begins. 2. It begins in the middle of the mode of Comp re-start prevention.	
8	Prevention of Comp	Comp	1. In order to protect Comp after Comp Off, it does not re-start for a certain time, though R-Sensor becomes On 2. Re-start Prevention Time 1) In case RT-Sensor temperature $\leq 13^{\circ}\text{C}$ (Low Temp. A) : 20 minutes 2) In case RT-Sensor temperature $\geq 14^{\circ}\text{C}$: 6minutes 3) In case RT-Sensor disconnection/short-circuit : 6 minutes	
9	Option Circuit	Nothing Concerned	1. Option for Weak Refrigeration 1) Regulation of R-Sensor Off Point 2) In case of Weak Refrigeration, take action as the followings.  ① Resistance (R16) : Standard Resistance(31.4 kΩ) of R-Sensor in case of Normal Run ② Resistance (R18) : Standard Resistance(21.5 kΩ) to make R-Sensor Off Point below 1.5°C in case of Weak Refrigeration ③ SW1 : In A/S, R-Sensor Off Point decreases by 1.5°C , if SW1 is made Off. R16 + SW1 = Middle Off Point R16 + R18 = Middle Off Point - 1.5°C	

NO	CONTROL FUNCTION	CONTROL OBJECTS	CONTENTS	REMARK																								
10	Error Display and How to Control it	LED	<p>1. Priority of Error Display R1 > D1 > D2 > C1 > A/S Compulsary Defrosting</p> <p>2. Display Mode</p> <table border="1" data-bbox="596 490 1289 909"> <thead> <tr> <th>Display Type</th> <th>LED Output Mode</th> </tr> </thead> <tbody> <tr> <td>R1 ERROR</td> <td></td> </tr> <tr> <td>D1 ERROR</td> <td></td> </tr> <tr> <td>D2 ERROR</td> <td></td> </tr> <tr> <td>C1 ERROR</td> <td></td> </tr> <tr> <td>A/S Compulsary Defrosting</td> <td></td> </tr> </tbody> </table> <p>3. R1 Error</p> <ol style="list-style-type: none"> Starting Condition : R-Sensor Disconnection/Short-circuit Display : Flickering once during LED Off How to control <table border="1" data-bbox="612 1077 1299 1196"> <thead> <tr> <th>RT-S</th> <th>ERROR</th> <th>~13℃</th> <th>14℃~19℃</th> <th>20℃~29℃</th> <th>29℃~</th> </tr> </thead> <tbody> <tr> <td>Running Ratio (ON/OFF)</td> <td>16/24</td> <td>6/34</td> <td>14/26</td> <td>16/24</td> <td>20/20</td> </tr> </tbody> </table> <ol style="list-style-type: none"> Ending Condition : ending automatically if R-Sensor is normal <p>4. D1 Error</p> <ol style="list-style-type: none"> Starting Condition : D-Sensor Disconnection/Short-circuit Display : Flickering twice during LED Off How to control : controlled by limit time of the return of defrosting(30 minutes) Ending Condition : ending automatically if D-Sensor is normal <p>5. D2 Error</p> <ol style="list-style-type: none"> Starting Condition : In Defrosting Mode, the return of Heater is done by limit time Display : Flickering 3 times during LED Off How to control : controlled by limit time of the return of defrosting <ol style="list-style-type: none"> D1 Error : 30 minutes Normal PCB Function (in case of Over Frosting/Heater Disconnection) : 80 seconds Ending Condition : ending automatically if Heater Off is done by D-Sensor temperature(10℃) at the next defrosting <p>6. C1 Error</p> <ol style="list-style-type: none"> Starting Condition : if Comp runs for 3 hours continuously when D-Sensor temperature is over -5℃ Display : continuous On of LED How to control : nothing to control by Micom Ending Condition <ol style="list-style-type: none"> ending automatically if Comp becomes Off by R-Sensor Off Point in case of D1 Error 	Display Type	LED Output Mode	R1 ERROR		D1 ERROR		D2 ERROR		C1 ERROR		A/S Compulsary Defrosting		RT-S	ERROR	~13℃	14℃~19℃	20℃~29℃	29℃~	Running Ratio (ON/OFF)	16/24	6/34	14/26	16/24	20/20	
Display Type	LED Output Mode																											
R1 ERROR																												
D1 ERROR																												
D2 ERROR																												
C1 ERROR																												
A/S Compulsary Defrosting																												
RT-S	ERROR	~13℃	14℃~19℃	20℃~29℃	29℃~																							
Running Ratio (ON/OFF)	16/24	6/34	14/26	16/24	20/20																							

DIAGRAM

1. WIRNIG DIAGRAM

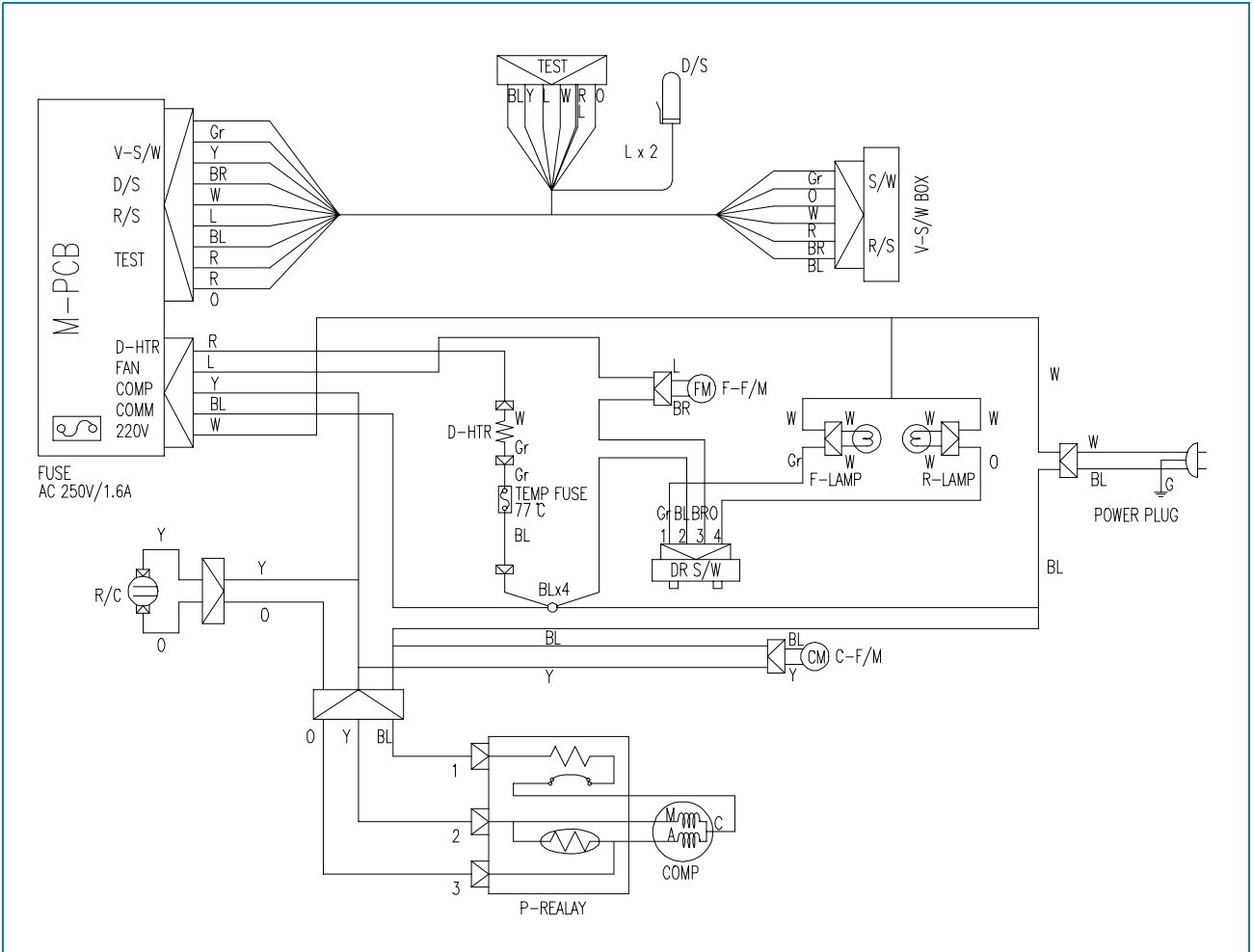

2. PARTICAL WIRING DIAGRAM

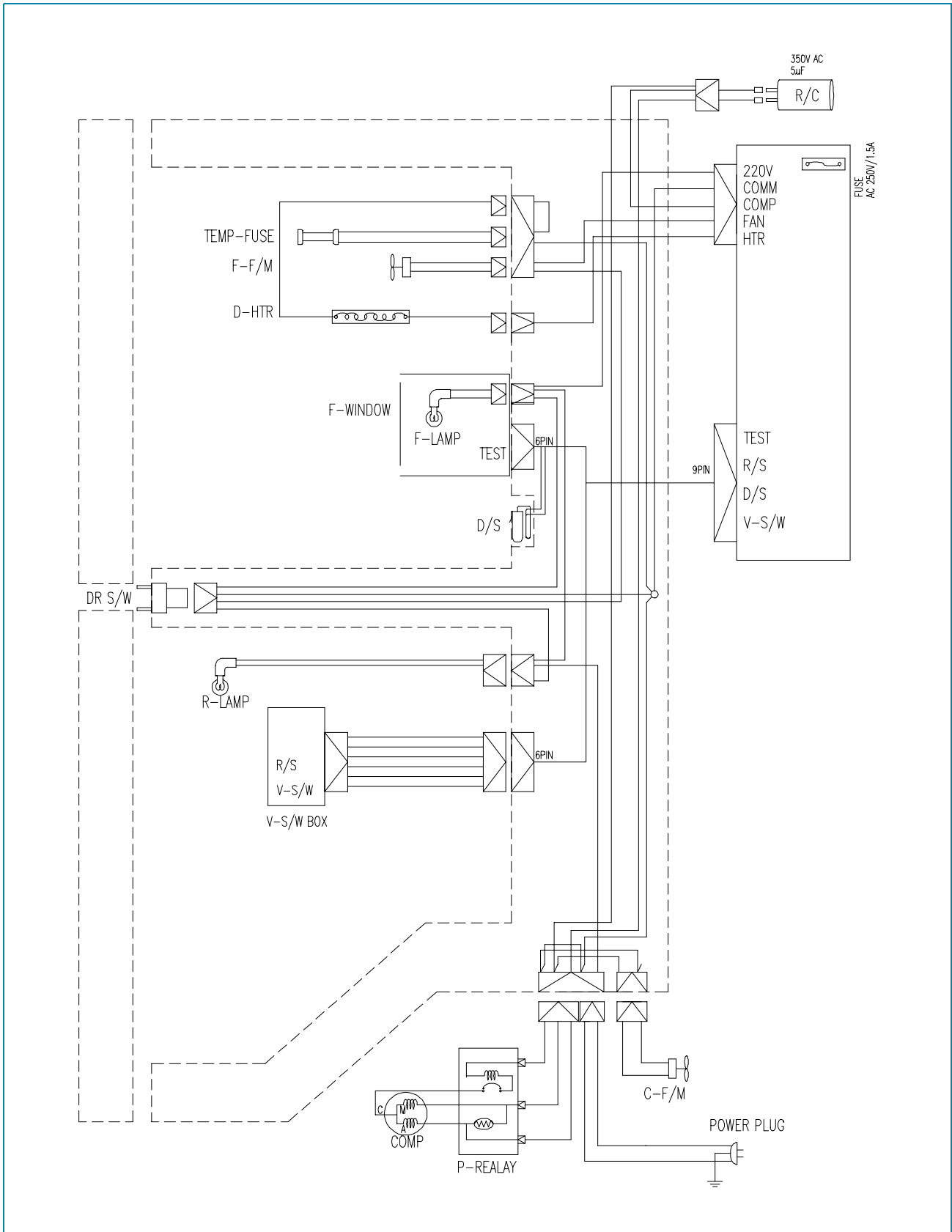

4. AIR FLOW DIAGRAM

Frezer

Please don't put bottles
such as beer, beverage etc.
It might be broken because of freezing.

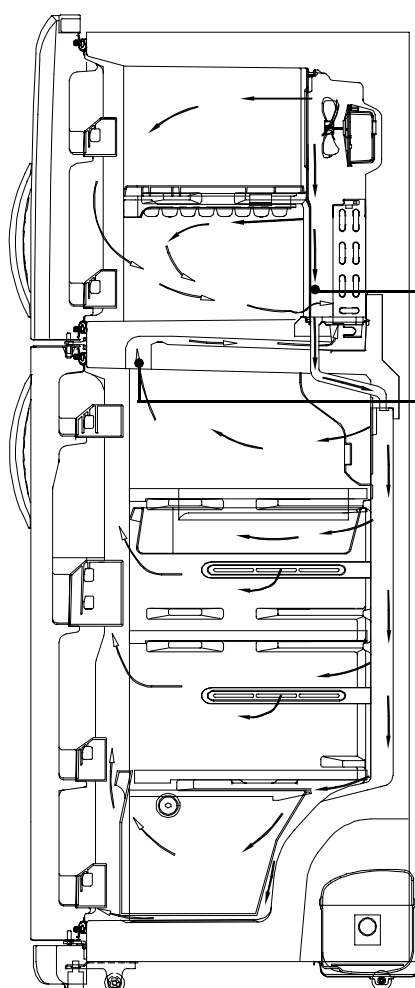
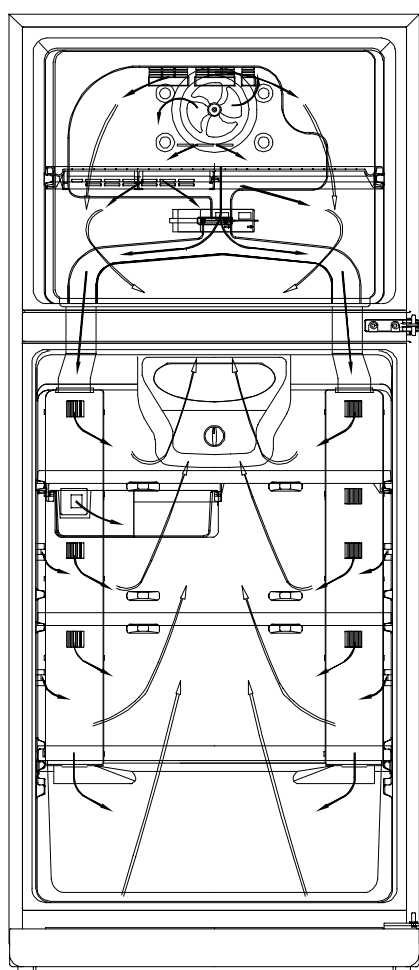

Inlet of cooling air
It should not be blocked with
food etc. as it is the inlet where
cooling air returns.

Multiple outlet of cooling air

Please don't put in vegetable etc.
which contain moisture.
It might be frozen because of low temperatuer.

5. REFRIGRANT CYCLE DIAGRAM

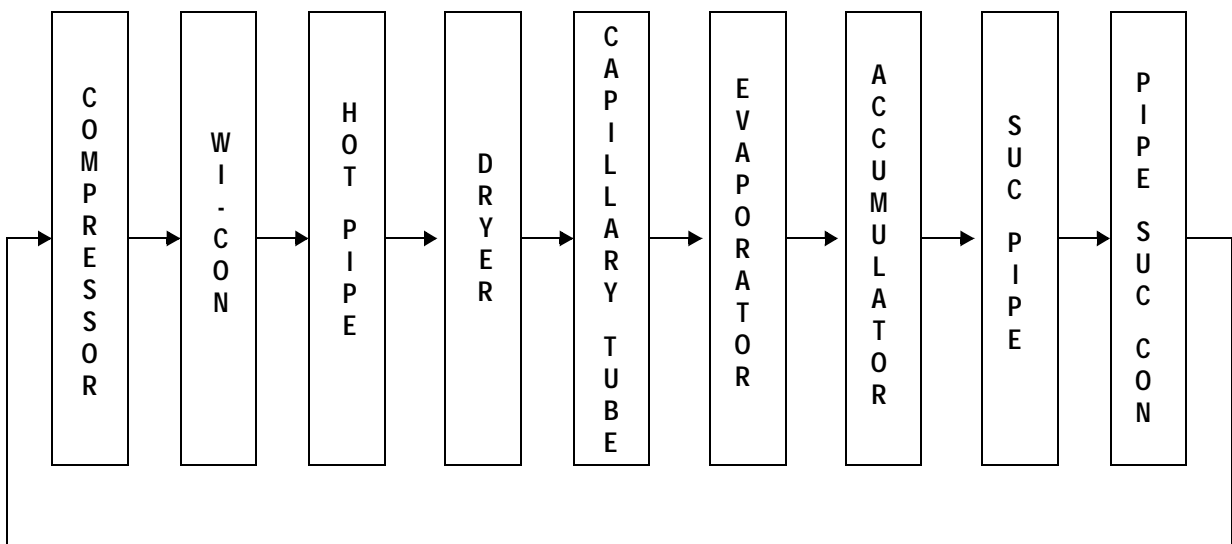
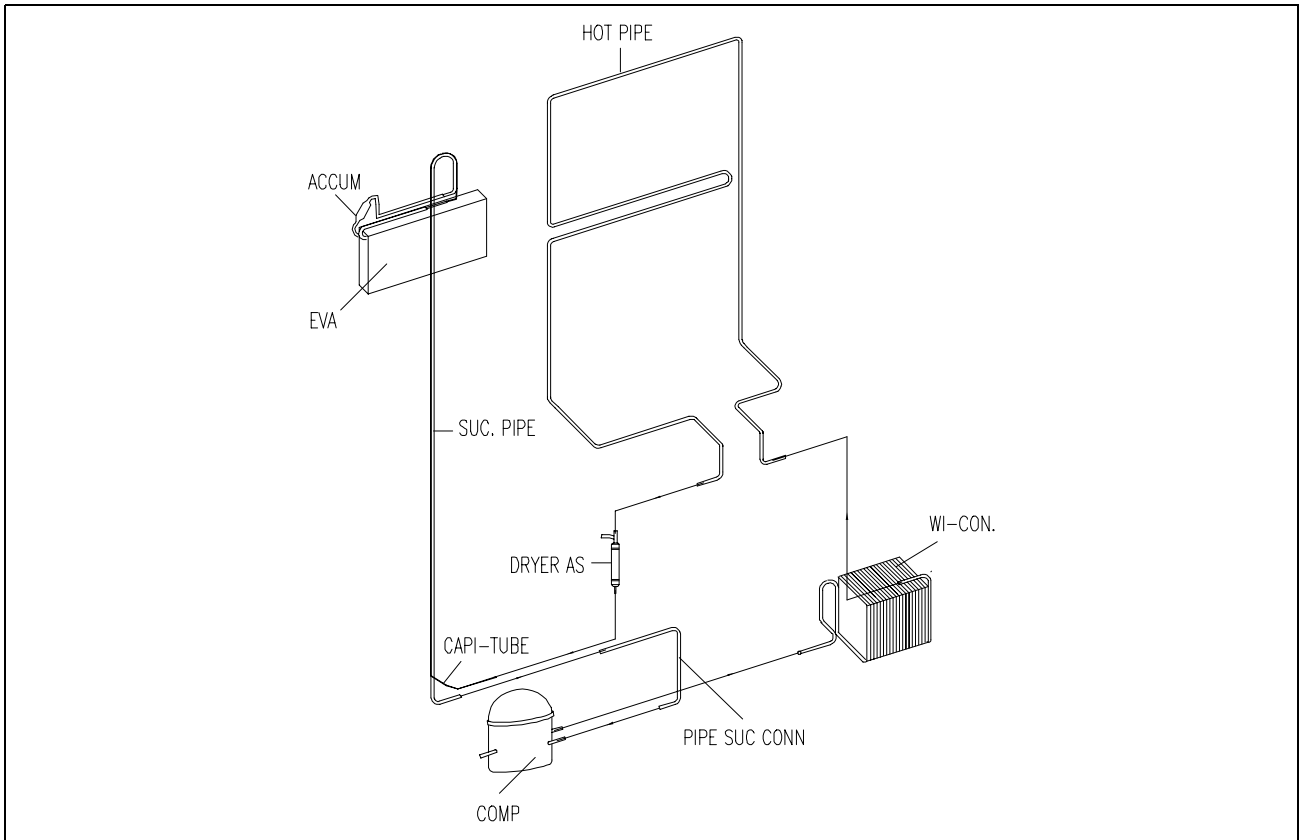

DISASSEMBLY AND ASSEMBLY

1. FREEZER LOUVER

1) FR-520NT, 550NT

- ① Push smoothly the locker of light bulb cover and Remove it.



- ② Remove the screw cover on the top left using screw driver ("- " type)



- ③ Remove the screw using screw driver.(" + " type)



- ④ Remove the screw on the light bulb base.



- ⑤ Pull the light housing by pressing the locker smoothly.



- ⑥ Remove the louver.



2. CONTROL SWITCH IN REFRIGERATOR ROOM

1) FR-520NT, 550NT

- ① Remove the light bulb cover by pushing the locker with screw driver.



- ② Turn the light bulb to the left to remove it.



- ③ Remove the screws on the light bulb base.



2. TOTAL PARTS LIST

NO	PART CODE	PART NAME	PART DESCRIPTION	QUANTITY	REMARK
1	3010074800	ASSY CAB URT	FR-520NT	1	
1	3010074900	ASSY CAB URT	FR-550NT	1	
2	3012910100	HINGE *T		1	
3	3016001230	SPECIAL BOLT T/U	6X22 SWCH22A(WH)	3	
4	3010511700	BOX M/PCB		1	
5		PCB MAIN AS		1	REFER TO #7
6	7112401211	SCREW TAPPING	MFZN, T1 TRS 4X12	3	
7		CAPACITOR		1	REFER TO #6
8	3011425300	COVER M/PCB BOX		1	
9	3012905501	HINGE *M		1	
10	3011424700	COVER *M HI		1	
11	3016001220	SPECIAL BOLT M	6X20 SWCH22A(WH)	3	
12	3018100030	SWITCH DR		1	
13	3012103000	FOOT *F *R AS		1	
14	3012102900	FOOT *F *L AS		1	
15	3016000700	SPECIAL SCREW	M6X15	2	
16	3012906410	HINGE *U AS		1	
17	3016005300	SPECIAL WASR		1	
18	3016001230	SPECIAL BOLT T/U	6X22 SWCH22A(WH)	3	
19	3012101500	FOOT ADJ AS		1	
20	3012102500	FOOT ADJ *L AS		1	
21	7112401211	SCREW TAPPING	MFZN, T1 TRS 4X12	2	
22	3011439900	COVER CAB BRKT		1	
23	3013202700	HOSE DRN B		1	
24	3012401400	GRILLE		1	
25	7112401211	SCREW TAPPING	MFZN, T1 TRS 4X12	6	
26		CORD POWER AS		1	REFER TO #9
27	7112401211	SCREW TAPPING	MFZN, T1 TRS 4X12	1	
28	7001400865	SCREW MACHINE	PAN 4X8 BSNI	1	
29	3011302900	FUSE GLASS TUBE		1	
30		DRYER AS		1	REFER TO #8
31	3014423900	PIPE WICON AS		1	
32	3011200500	CLAMP FAN		1	
33	3011800400	FAN		1	
34		MOTOR C		1	REFER TO #7
35	3012004400	FIXTURE C MOTR		1	
36	3010102100	ABSORBER C MOTR		1	
37	3011118000	CASE VAPORI		1	

EXPLODED VIEW AND PARTS LIST

NO	PART CODE	PART NAME	PART DESCRIPTION	QUANTITY	REMARK
38	7112401211	SCREW TAPPING	MFZN, T1 TRS 4X12	2	
39		COMPRESSOR		1	REFER TO #5
40		SWITCH P RELAY AS		1	REFER TO #5
41	3012610000	CLAMP BAND RELAY		1	
42	4010G01123	SPECIAL BOLT		1	
43	3010314900	BASE COMP		1	
44	3016500000	CASTER *B		2	
45	3014902900	SHAFT CASTR *B		2	
46	3016003300	SPECIAL BOLT	T2 M6.5X20	4	
47	3016003400	SPECIAL BOLT	T1 M5.0X14	1	
48	3011110200	CASE ICING		2	
49	3011439800	COVER ICE BOX		1	
50	3010513000	BOX ICE		1	
51	3017807500	SHELF F		1	
52	3015504200	WINDOW F		1	
53	3013600030	LAMP AS	240V/15W (E14)	1	
54	3017903400	SOCKET F LAMP AS		1	
55	3018902700	LOUVER F		1	
56	7112401811	SCREW TAPPING	MFZN, T1 TRS 4X18	2	
57	3010924600	CAP F LUVR		1	
58	3013402100	KNOB F CONTL		1	
59	3013331700	INSU F LUVR		1	
60	3011800400	FAN		1	
61	3012007300	FIXTURE MOTR B		1	
62	3012004001	FIXTURE MOTR		1	
63	7112401611	SCREW TAPPING	MFZN, T1 TRS 4X16	3	
64	3018700100	DEODRANT AU RETURN		1	
65	3018700700	DEODRANT SHEET		1	
66	3011102501	CASE DEO A		1	
67	3010512900	BOX V/SW PCB		1	
68	3014305400	PCB V/SW AS		1	
69	3017903300	SOCKET R LAMP AS		1	
70	3013600030	LAMP AS	240V/15W (E14)	1	
71	3012720600	HARNESS V/SW AS		1	
72	3011439600	COVER PCB V/SW BOX		1	
73	3013402000	KNOB CONTL		1	
74	7112401211	SCREW TAPPING	MFZN, T1 TRS 4X12	1	
75	3015504000	WINDOW R		1	
76	3018906400	LOUVER R *S *R	FR-520NT	1	

NO	PART CODE	PART NAME	PART DESCRIPTION	QUANTITY	REMARK
76	3018902600	LOUVER R *S *R	FR-550NT	1	
77	3013331200	INSU R *S *R	FR-520NT	1	
77	3013331000	INSU R *S *R	FR-550NT	1	
78	3018906300	LOUVER R *S *L	FR-520NT	1	
78	3018902500	LOUVER R *S *L	FR-550NT	1	
79	3013331100	INSU R *S *L	FR-520NT	1	
79	3013330900	INSU R *S *L	FR-550NT	1	
80	3011439500	COVER CUBIC/D		4	
81	3014700600	ROLLER V/CASE FIXR		2	
82	3015303600	SUPPORTER V/CASE ROL		2	
83	7112402011	SCREW TAPPING	MFZN, T1 TRS 4X20	2	
84	3017802300	SHELF R *T		1	
85	3011117800	CASE CHILLED		1	
86	3017805100	SHELF R *U		1	
87	3011439700	COVER V/CASE		1	
88	3014700500	ROLLER V/CASE		2	
89	3011432800	COVER ROLL A		2	
90	3011117700	CASE VEGETB		1	
91	3019011000	POCKET MULT	GPPS, FR-520NT(3)	1	
91	3019011000	POCKET MULT	GPPS, FR-550NT(3, 4)	2	
92	3012505700	GUIDE JUMBO POCKT		1	
93	3019010900	POCKET JUMBO		1	
94	3019008900	POCKET EGG		2	
94	3019008900	POCKET EGG		1	
95	3011117600	CASE EGG		2	
96	3012304400	GASKET R DR AS	FR-520NT	1	
96	3012301700	GASKET R DR AS	FR-550NT	1	
97		ASSY R DR		1	REFER TO #10
98	3012610600	HANDLE R		1	
99	7051501611	SCREW MACHINE	MFZN, PAN 5X16 SW FRB-5460CT	4	
100	3011608400	DECO R HNDL		1	
101	3019011100	POCKET F		2	
102	3012301400	GASKET F DR AS		1	
103		ASSY F DR		1	REFER TO #10
104	3012610500	HANDLE F		1	
105	3011608300	DECO F HNDL		1	
106	3014516740	PLATE TANK EBLM AS		1	

3. MACHINE ROOM EXPLODED VIEW AND PARTS LIST

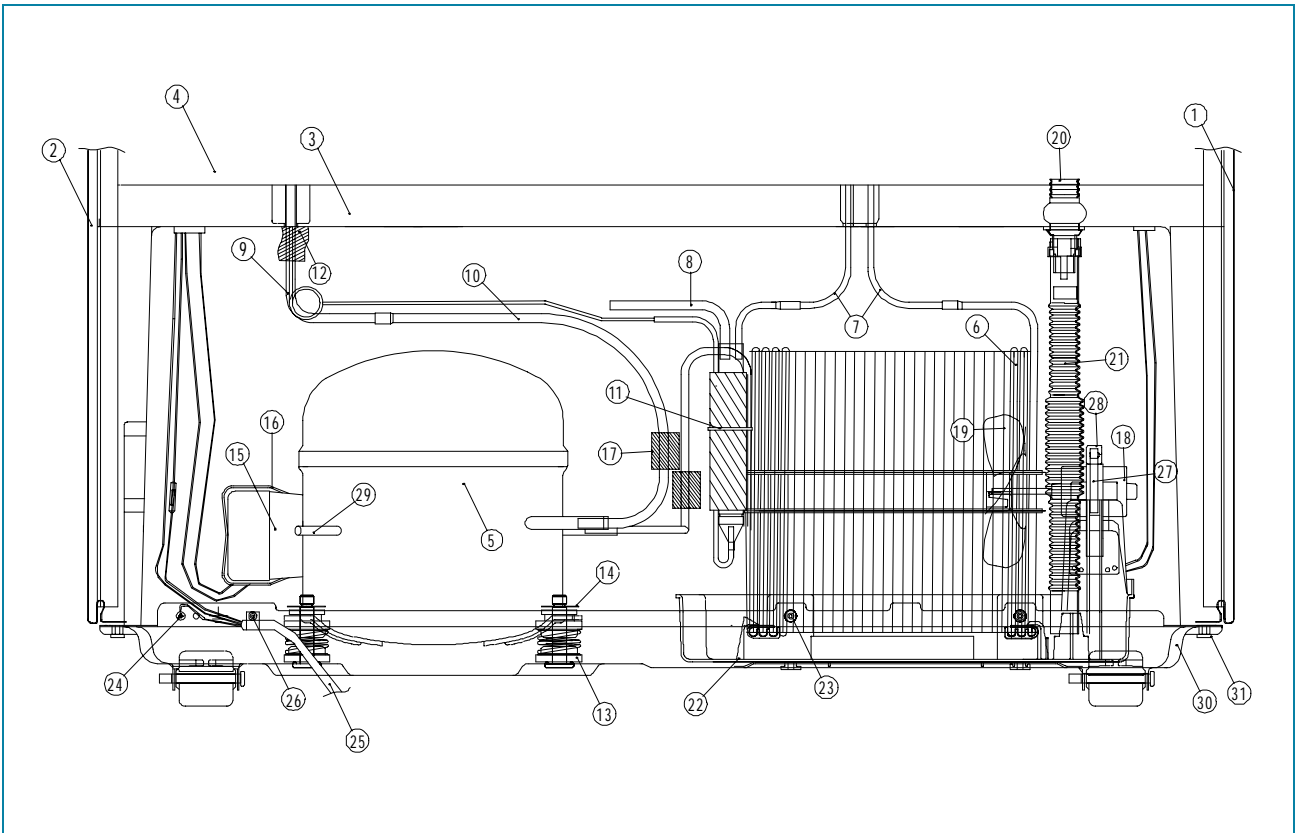

NO	PART NAME	NO	PART NAME	NO	PART NAME
1	PLATE CAB *L	11	CABLE TIE	21	HOSE DRN B
2	PLATE CAB *R	12	ABSORBER PIPE	22	CASE VAPORI
3	BASE CAB	13	ABSORBER COMP AS	23	SCREW TAPPING
4	COVER CAB	14	WASHER SPECIAL	24	SCREW MACHINE
5	COMPRESSOR	15	WSWITEC P-RELAY AS	25	CORD POWER AS
6	PIPE WI-CON AS	16	BAND RELAY	26	SCREW TAPPING
7	PIPE HOT	17	ABSORBER PIPE A	27	FIXTURE C MOTOR
8	DRYER AS	18	MOTOR C	28	ABSORBER C MOTOR
9	PIPE SUCTION AS	19	FAN	29	PIPE SERVICE
10	PIPE SUC CONN	20	HOSE DRN A	30	BASE COMP AS

